

Instruction Manual for M67 to M52 / M52 to M67 Adaptor Ring

PN#38020/38024

FOREWORD

Thank you for your purchase of a NAUTICAM product.

At NAUTICAM, we pride ourselves in the ability to recognize the requirements of professional as well as amateur underwater photographers and fulfill them through the innovative designs of our products. We strive to achieve a high level of user-friendliness by allowing stress-free installation and easy operation of all important functions of the camera.

Please read this manual carefully before using the product, this will maximize its performance as well as its lifetime.

WARRANTY

All NAUTICAM Products are warranted against any material and manufacturing defects for two years from the date of purchase for consumer use. This warranty only applies to products purchased from authorized NAUTICAM dealers and does not extend beyond the original retail purchaser.

To return your product for service, please contact your regional authorized service center(s). Please note that this warranty only applies when the product is purchased in the territory where the service center is located.

NAUTICAM does not hold responsibility for damage, of any nature, to any equipment used with and/or placed within our products.

NAUTICAM accepts no liability for any loss of captured images or the inability to capture images even if it is due to the malfunctioning of our products.

Unauthorized modifications and/or repairs of our products will automatically invalidate the warranty.

IDENTIFICATION OF PARTS

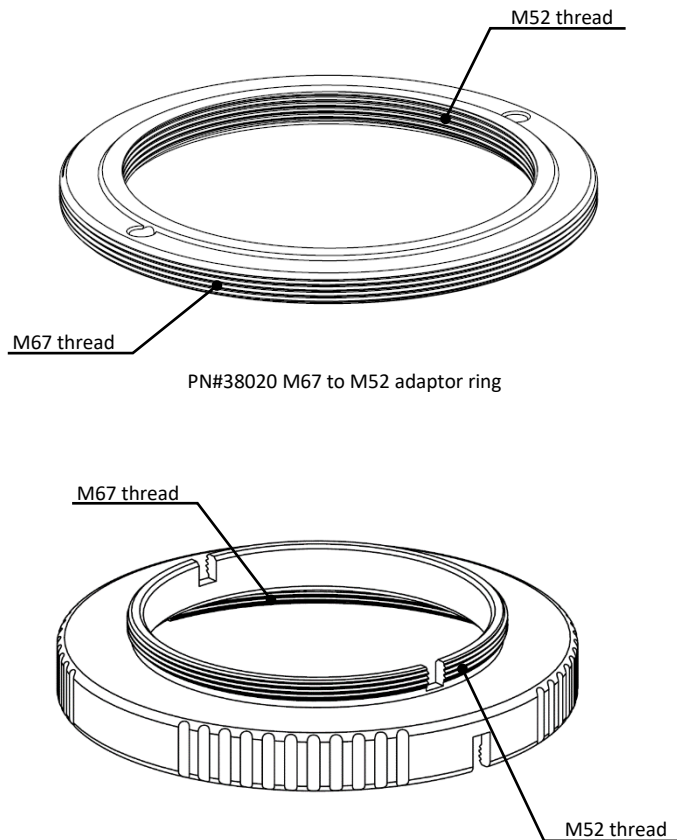

PN#38020 M67 to M52 adaptor ring

PN#38024 M52 to M67 Step Up Adaptor Ring

*PN#38020 is used as an example in this instruction manual, PN#38024 will be slightly different in term of appearance.

MOUNT THE ADAPTOR RING TO A HOUSING

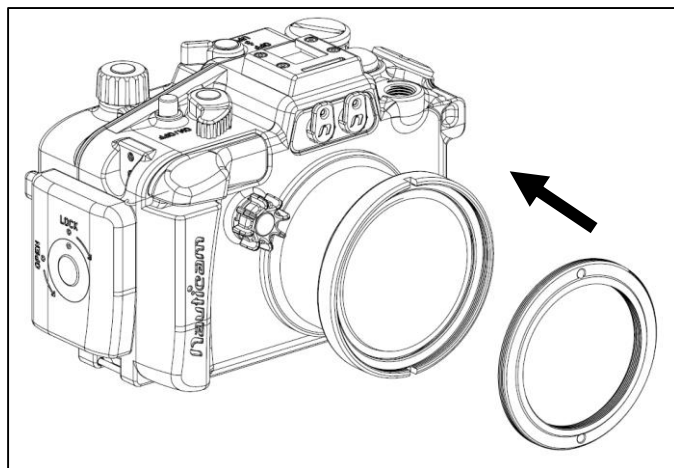

Attach the M67 to M52 adaptor ring to a housing as shown.

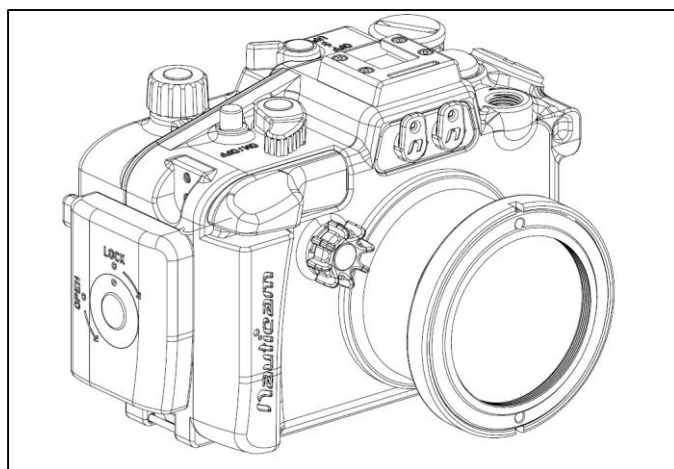

Fastening the M67 to M52 adaptor ring tightly on a housing.

SPECIFICATIONS

#38020 M67 to M52 adaptor ring

Diameter(mm):	DIA67.0 x 4.5
Weight(kg):	0.02
Material:	Aluminium Alloy
Compatibility:	For Housings, Ports are coming with M67 thread.

#38024 M52 to M67 Step Up Adaptor Ring

Diameter(mm):	DIA71.0 x 12.5
Weight(kg):	0.03
Material:	Aluminium Alloy
Compatible Housings:	17812 NA-TG6 housing (M52 mount)

Remark: Nauticam supports only e-manuals. Please download corresponding product manuals on google drive <https://bit.ly/Nauticammanual>, or contact us for e-manuals.